

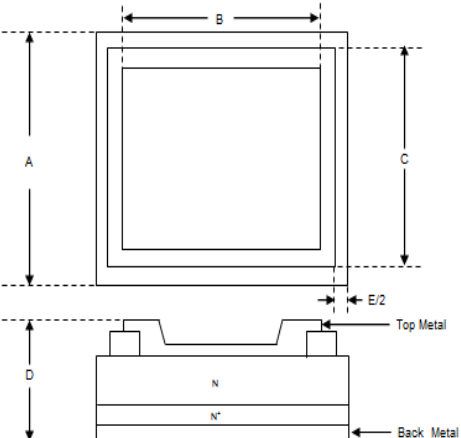

# TSB82T100S(A)S-255C

10A/100V<sup>(1)</sup>, low VF Schottky barrier diode with trench MOS structure

## Mechanical Data

Chip Drawing	Item	Information	
	Die Size (A)	2082 $\mu\text{m}$	82 mil
	Top Metal Pad Size (B)	1950 $\mu\text{m}$	77 mil
	Chip Size (C)	2002 $\mu\text{m}$	79 mil