

YJ



YJG50N03B

Electrical Characteristics ($T_J=25$ unless otherwise noted)



Typical Performance Characteristics

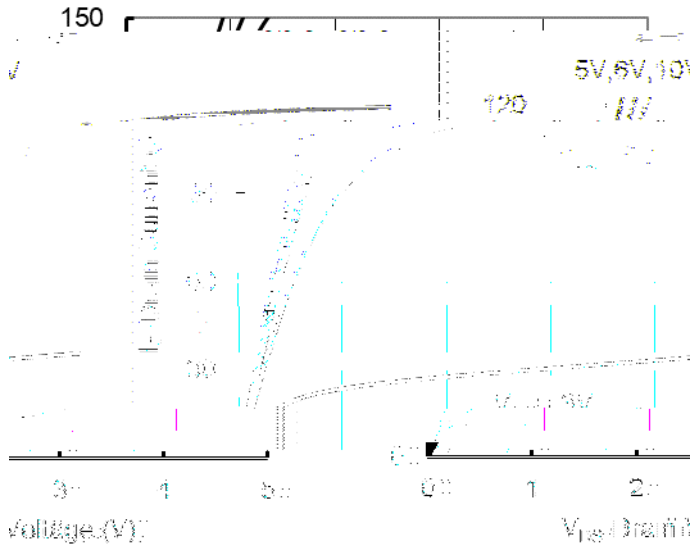

Figure 1. Output Characteristics

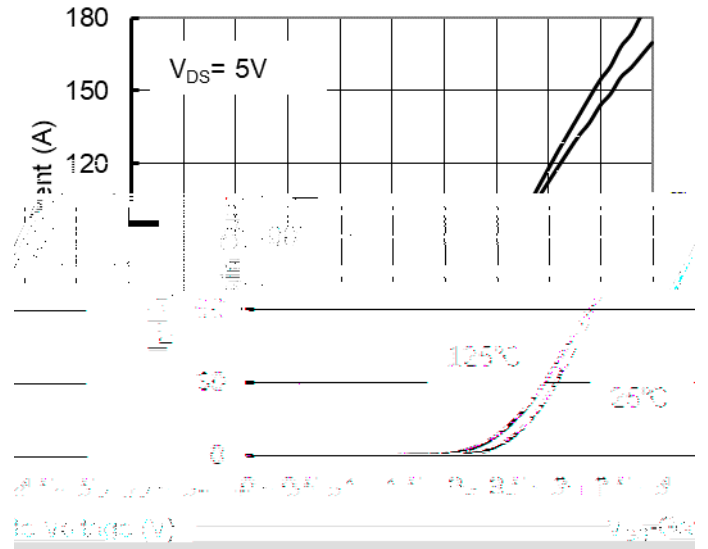

Figure 2. Transfer Characteristics

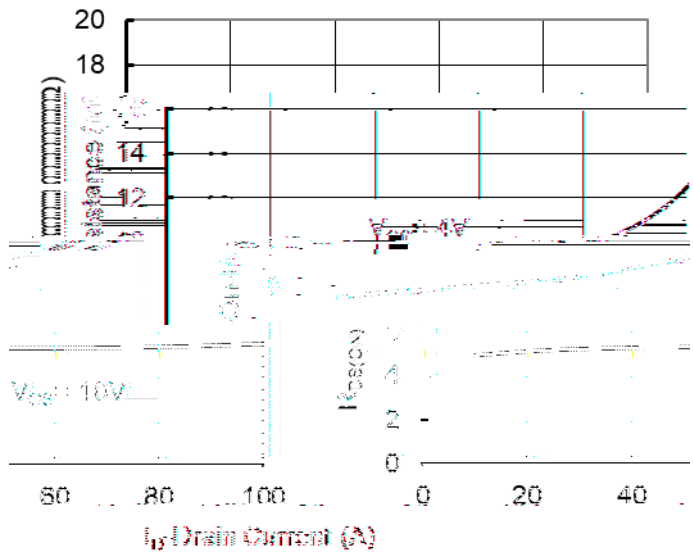

Figure 3. On-Resistance vs. Drain Current and Gate Voltage

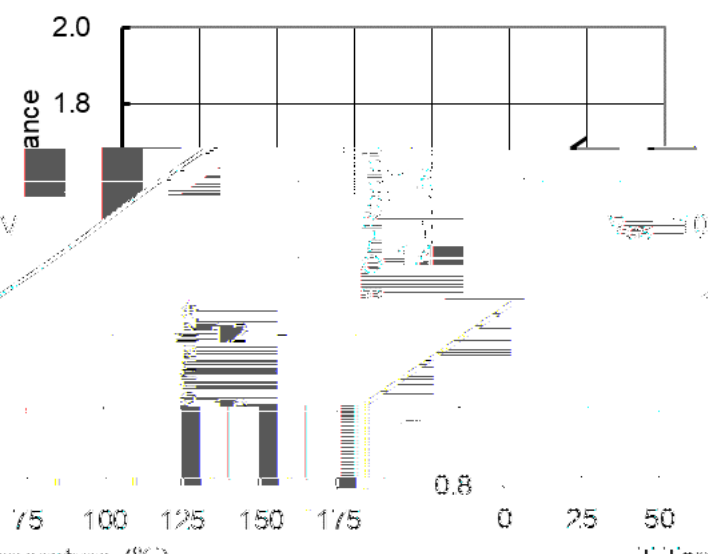

Figure 4. On-Resistance vs. Junction Temperature

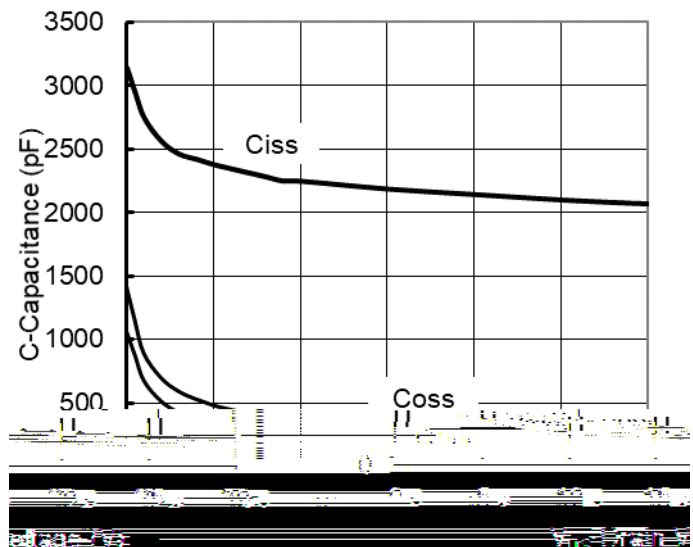

Figure 5. Capacitance Characteristics

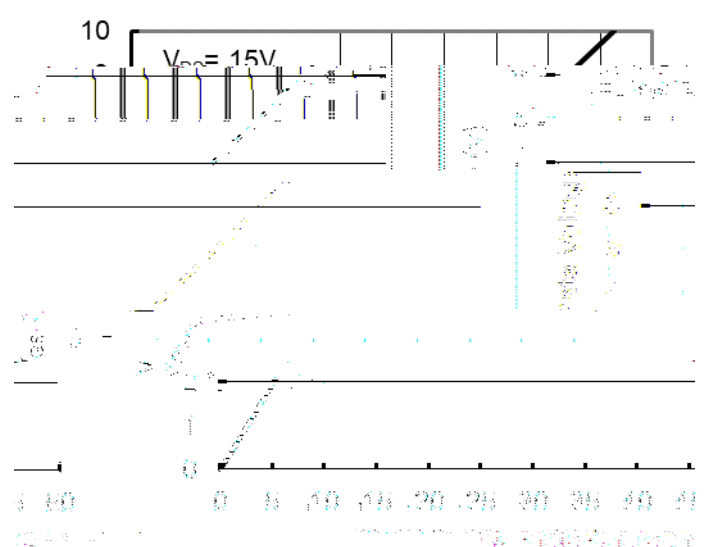
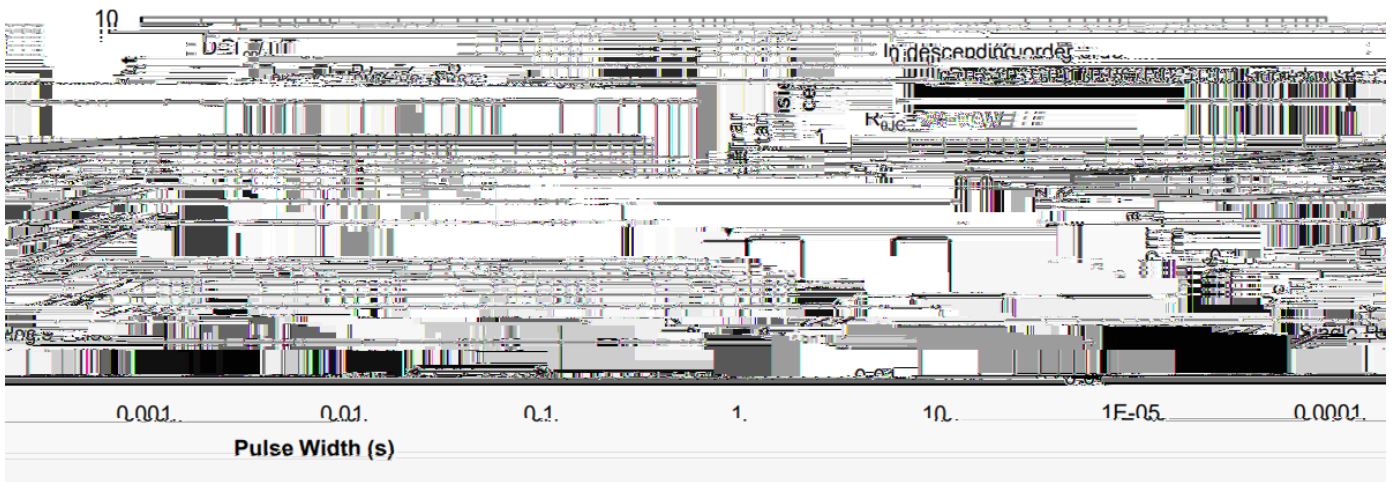

Figure 6. Gate Charge



Figure 7. Safe Operation Area

Figure 8. Maximum Continuous Drain Current vs Case Temperature



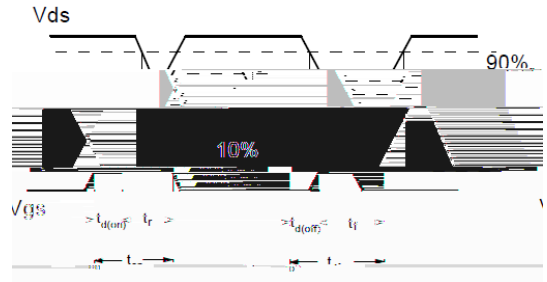
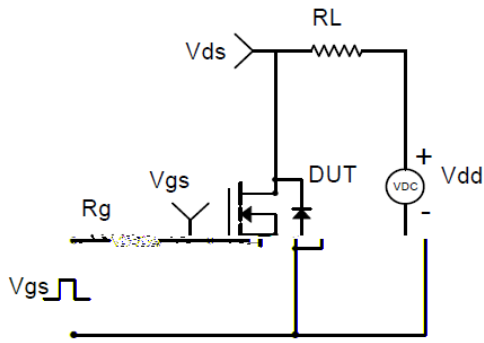

Resistive Switching Test Circuit & Waveforms

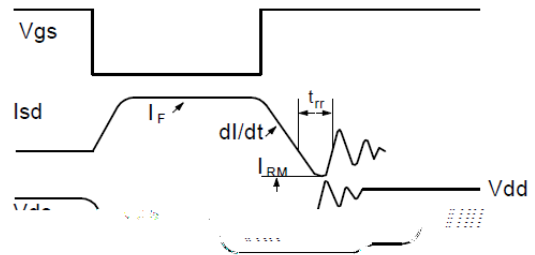
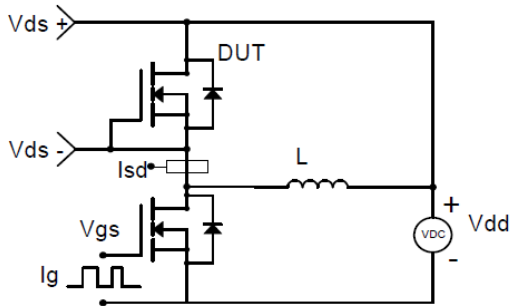

Diode Recovery Test Circuit & Waveforms

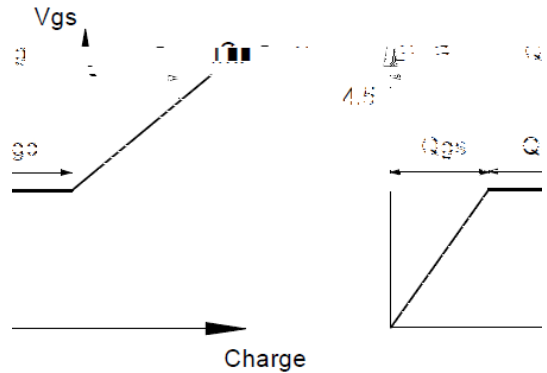
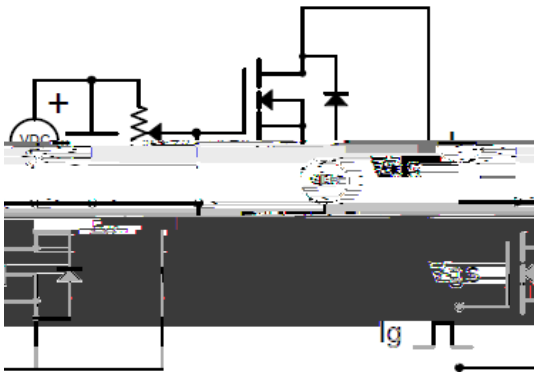

Gate Charge Test Circuit & Waveform

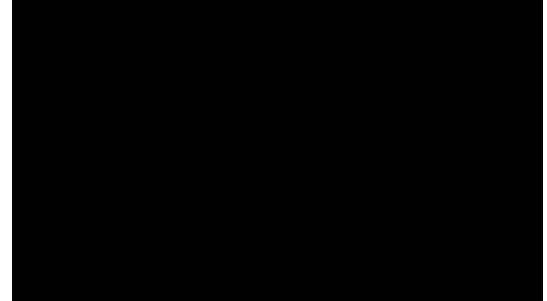
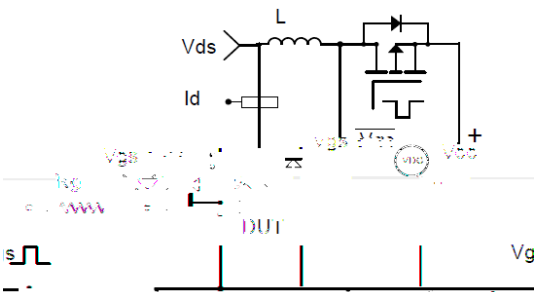

Unclamped Inductive Switching (UIS) Test Circuit & Waveforms



YJG50N03B

PDFN5060-8L-B-1.1MM Package Information

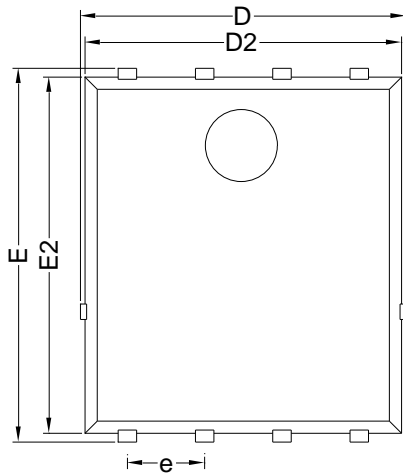

Top View

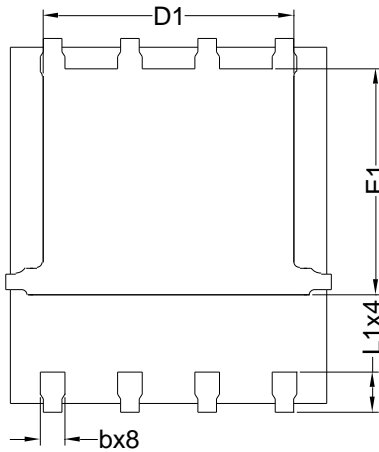

Bottom View

Side View

SYMBOL	MILLIMETER		
	MIN	NOM	MAX
D	5.15	5.35	5.55
E	5.95	6.15	6.35
A	1.00	1.10	1.20
A1	0.254 BSC		
A2			0.10
D1	3.92	4.12	4.32
E1	3.52	3.72	3.92
D2	5.00	5.20	5.40
E2	5.66	5.86	6.06
E3	0.254 REF		
E4	0.21 REF		
L1	0.56	0.66	0.76
L2	0.50 BSC		
b	0.31	0.41	0.51
e	1.27 BSC		

Note:

1. Controlling dimension: in millimeters.
2. General tolerance: ± 0.10 mm.
3. The pad layout is for reference purposes only.



Disclaimer

TheQeQ2Th10p1(T0 n[rTf1 -Qq3 0 15)11(T)6n6(h10.)5(2)p[rT-QG[sG[nq3 0 (T0 G[dh10.)5(2)11(T)6(h10.)5(2)0 15)0 11(T)6s)260.)5(2)dh10