

)LJXUH 6DIH 2SHUDWLRQ \$UHD-LJXUH 0D[LPXP &RQWLQXR XV 'UDL
YV \$PELHQW 7HPSHUDWXUH

)LJXUH 1RUPDOL]HGDQYLPHQFW77KHUPDO ,PSHGDQFH

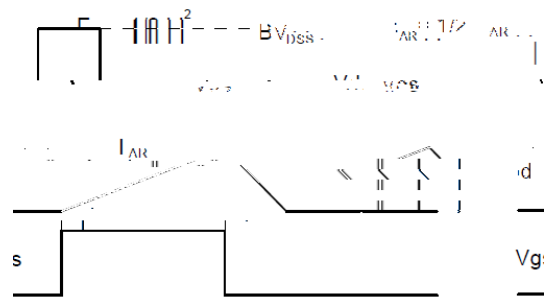

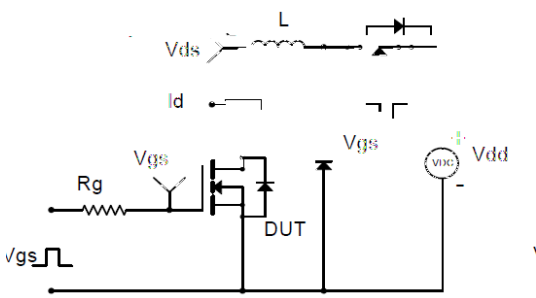
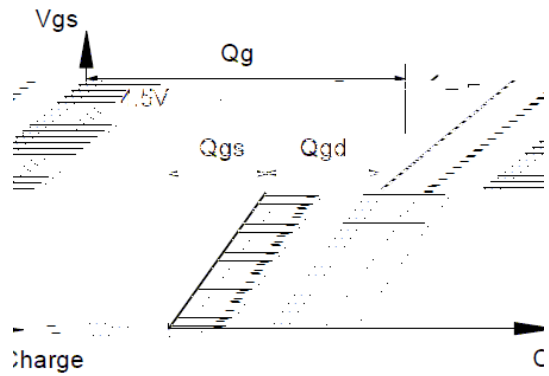
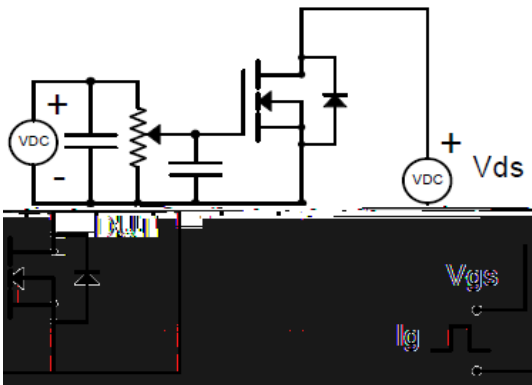
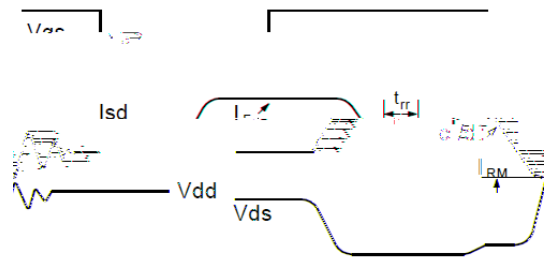
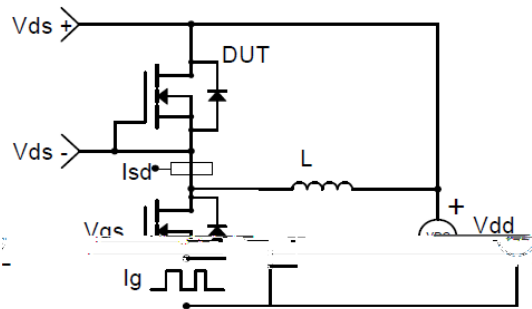
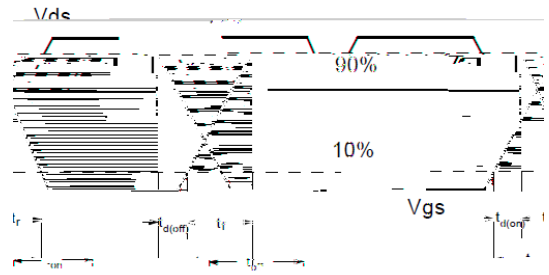
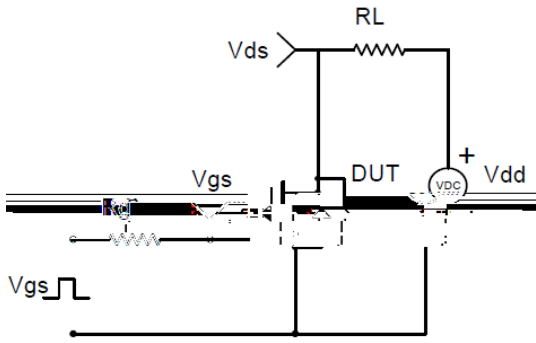

b	
D1	
