

| | |
|------------------------------------|-------------|
| V_{DS} | 20V |
| I_b | 80A |
| $R_{DS(on)}$ (at $V_{GS} = 4.5V$) | 18mΩ |
| $R_{DS(on)}$ (at $V_{GS} = 2.5V$) | 22mΩ |
| $R_{DS(on)}$ (at $V_{GS} = 1.8V$) | 30mΩ |

Trench Power LV MOSFET technology
 High density cell design for low $R_{DS(on)}$
 High Speed switching

Battery protection
 Load switch
 Power management

($T_A = 25$ unless otherwise noted)

| | | | |
|-----------------------------|----------|-----------|----------------|
| | | | |
| Drain-source Voltage | V_{DS} | 20 | V |
| Gate-source Voltage | V_{GS} | 10 | V |
| Drain Current | I_b | 8 | % A |



(T_F=25 unless otherwise noted)

| | | | | | | | | | |
|--|--|--|--|--|--|--|--|--|--|
| | | | | | | | | | |
|--|--|--|--|--|--|--|--|--|--|

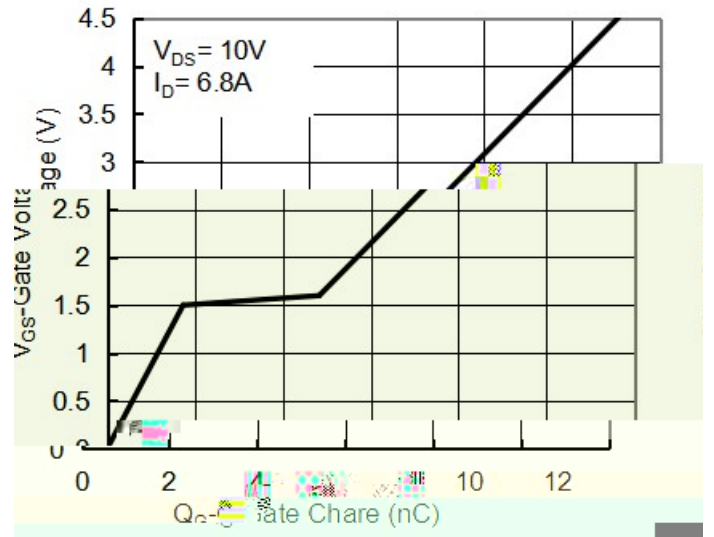
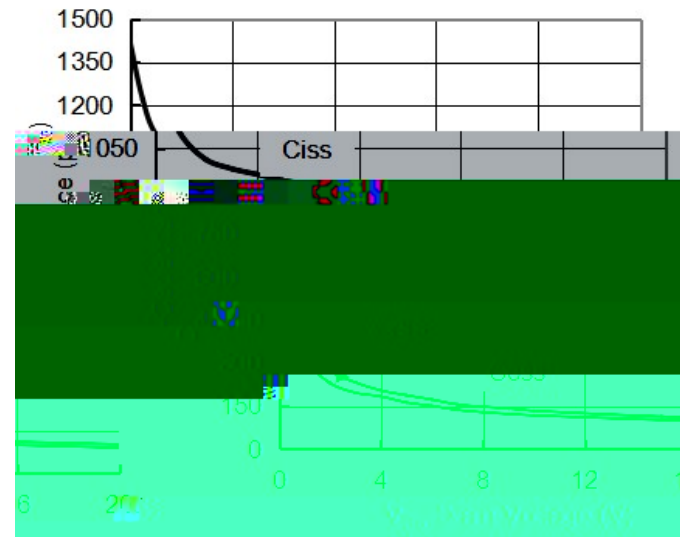
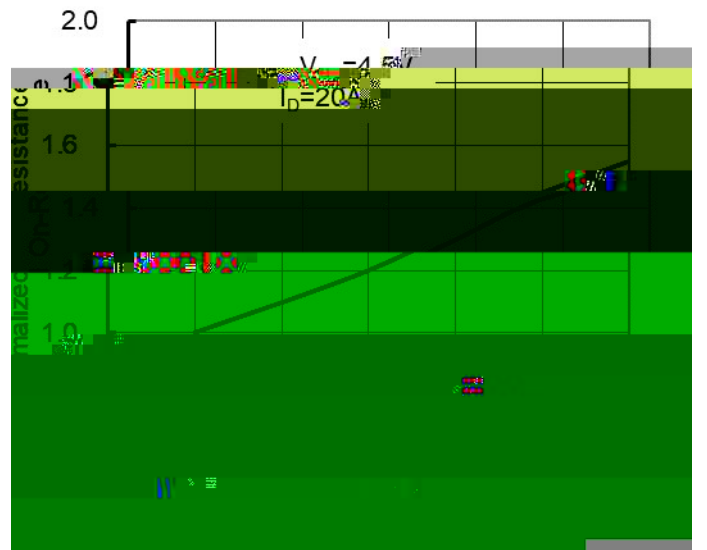
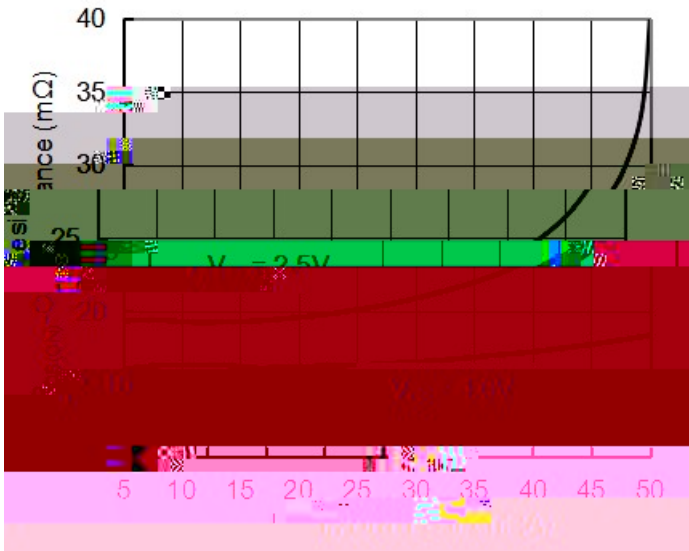
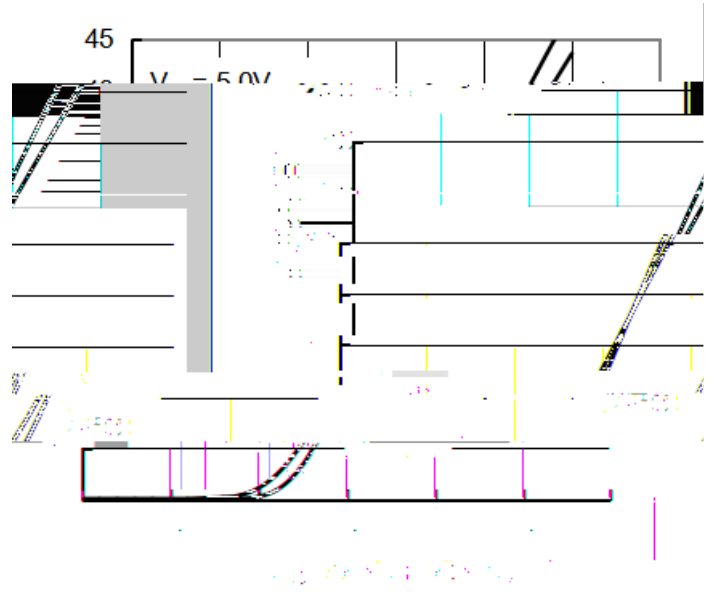
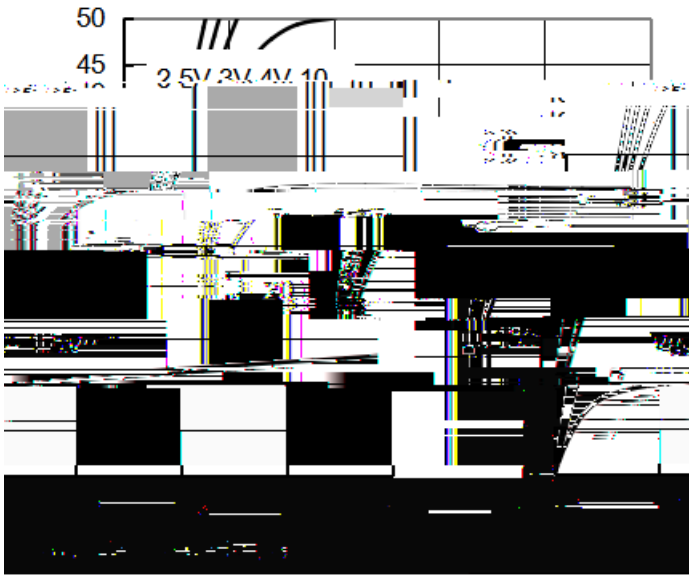

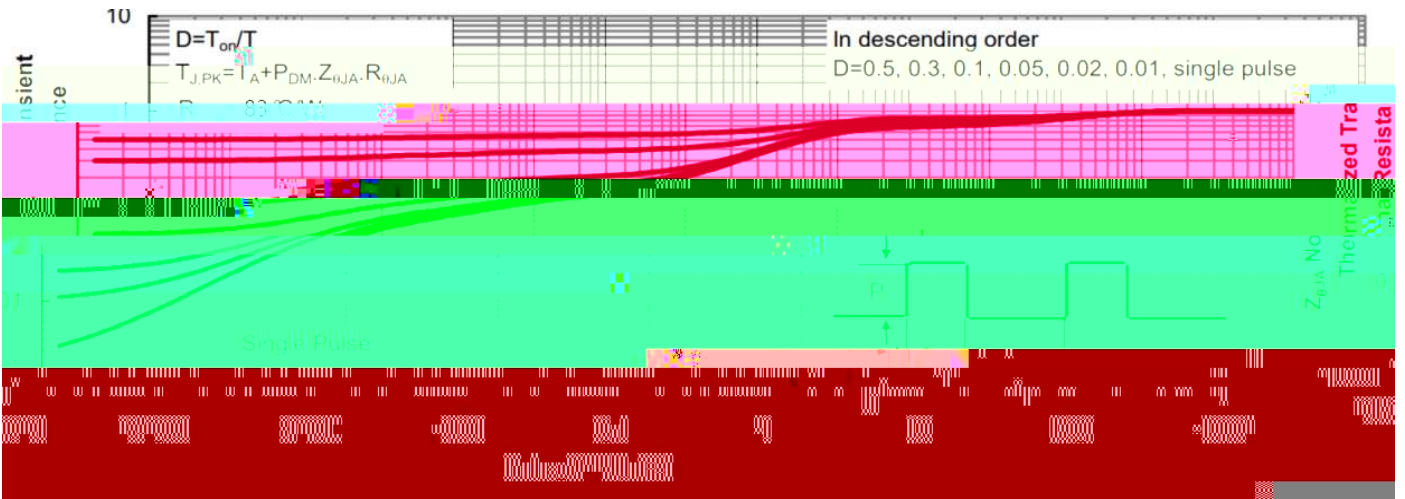
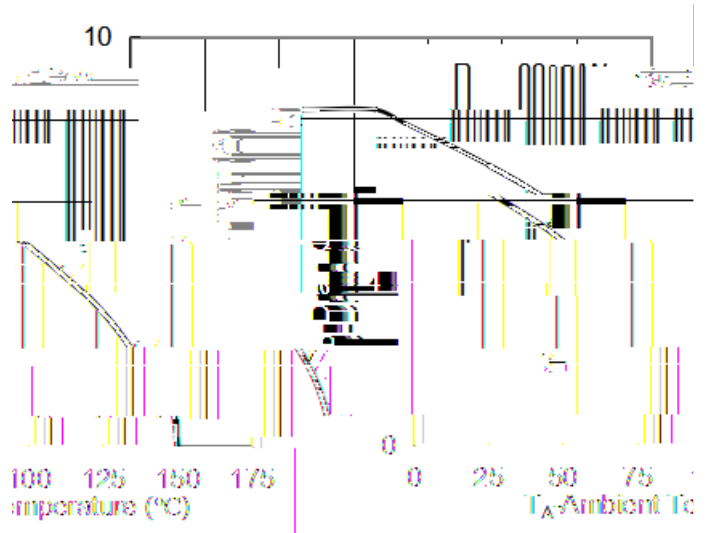
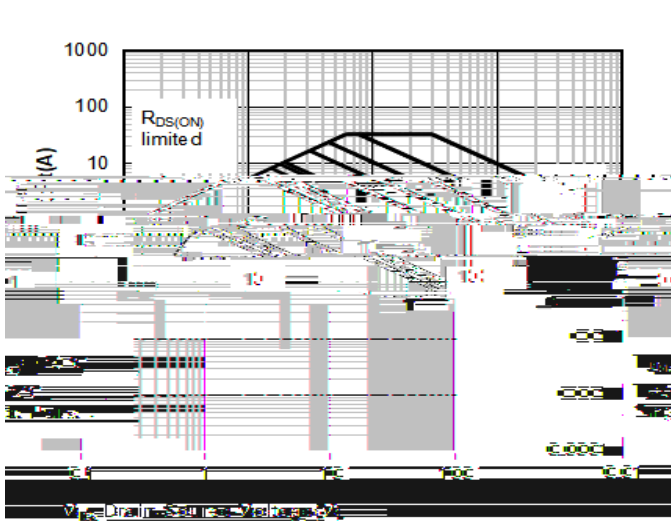

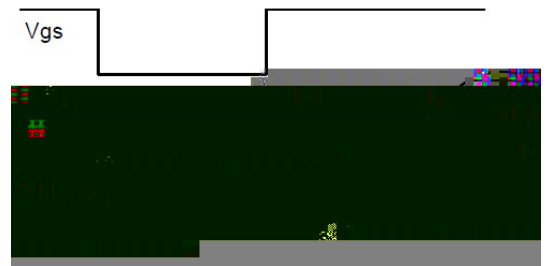
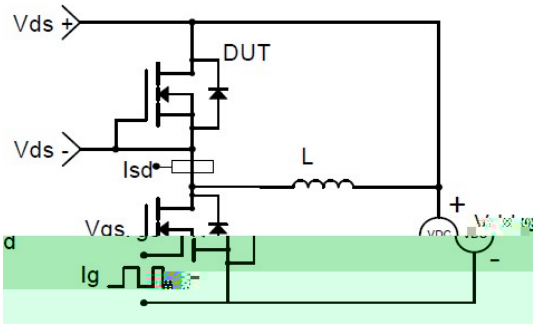
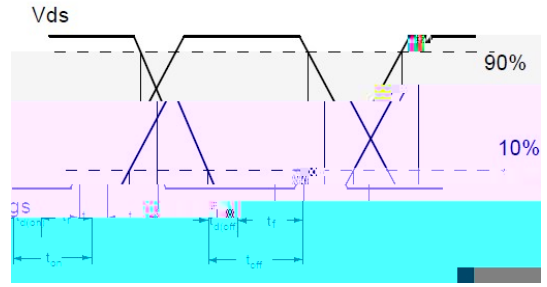
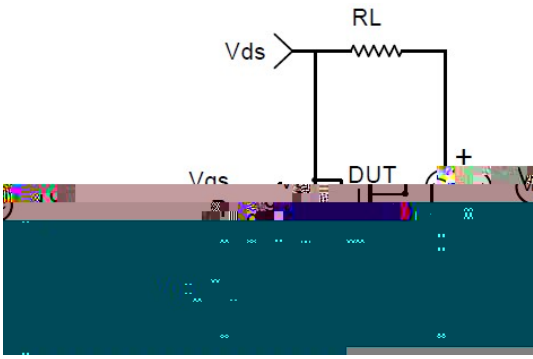

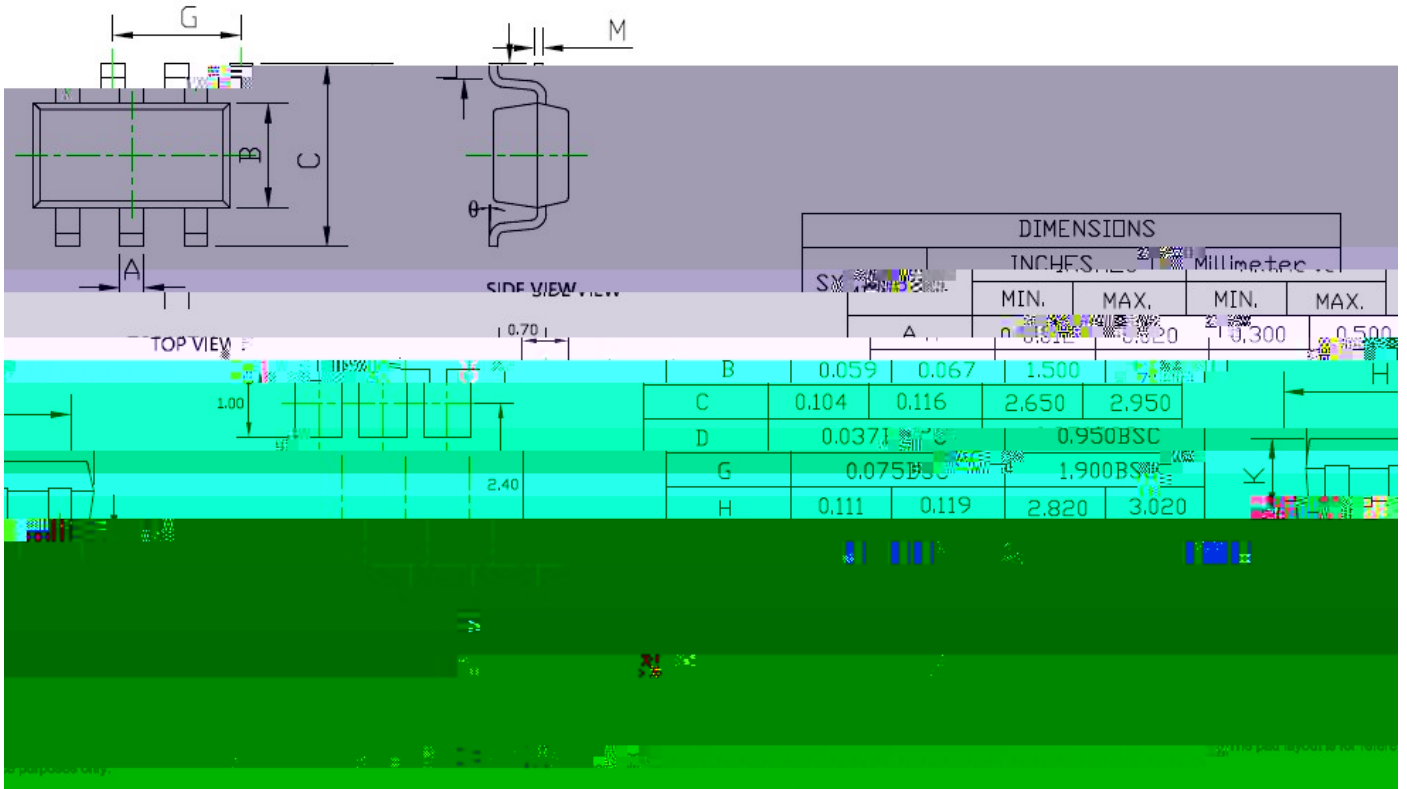



The information presented in this document is for reference only. Yangzhou Yangjie Electronic Technology Co, Ltd reserves the right to make changes without notice for the specification of the products displayed herein to improve reliability, function or design or otherwise.

The product listed herein is designed to be used with ordinary electronic equipment or devices, and not designed to be used with equipment or devices which require high level of reliability and the malfunction of which would directly endanger human life (such as medical instruments, transportation equipment, aerospace machinery, nuclear reactor controllers, fuel controllers and other safety devices), Yangjie or anyone on its behalf, assumes no responsibility or liability for any damages resulting from such improper use of sale.

This publication supersedes & replaces all information previously supplied. For additional information, please visit our website <http://www.21yangjie.com>, or consult your nearest Yangjie's distributor.