



YJP90G12H

Electrical Characteristics

Parameter	Symbol	Conditions	Min	Typ	Max	Units
Static Parameter						



YJP90G12H

Typical Electrical and Thermal Characteristics Diagrams

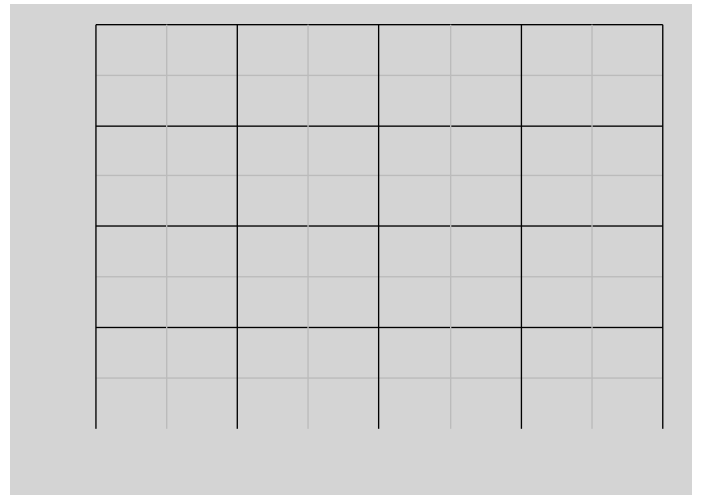
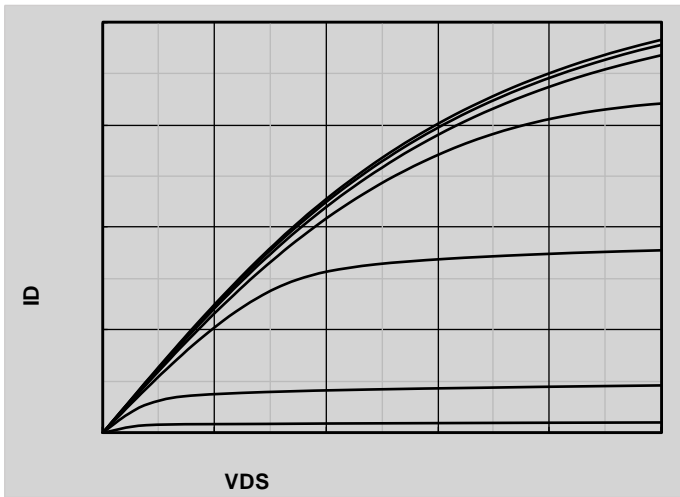



YJP90G12H

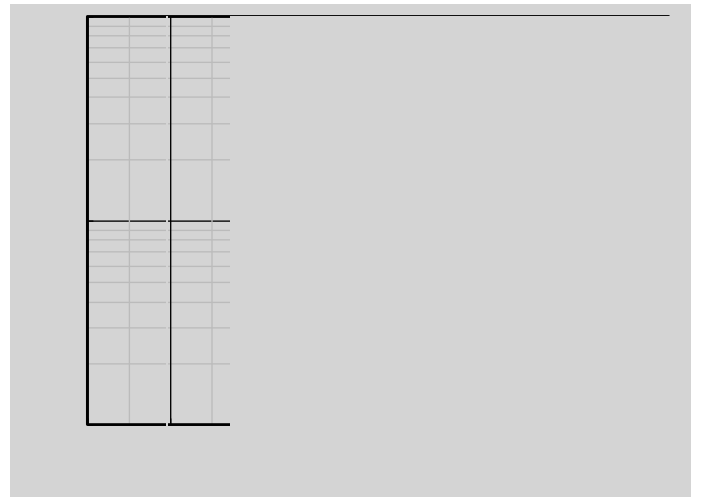
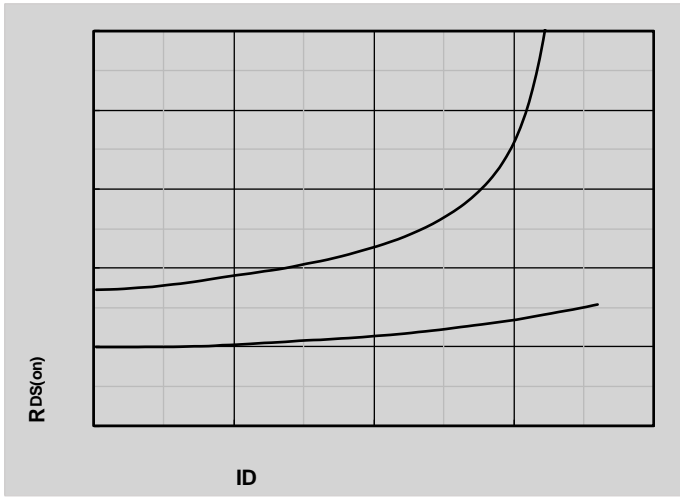

YJP90G12H

YJP90G12H



YJP90G12H

TO-220AB-C Package information

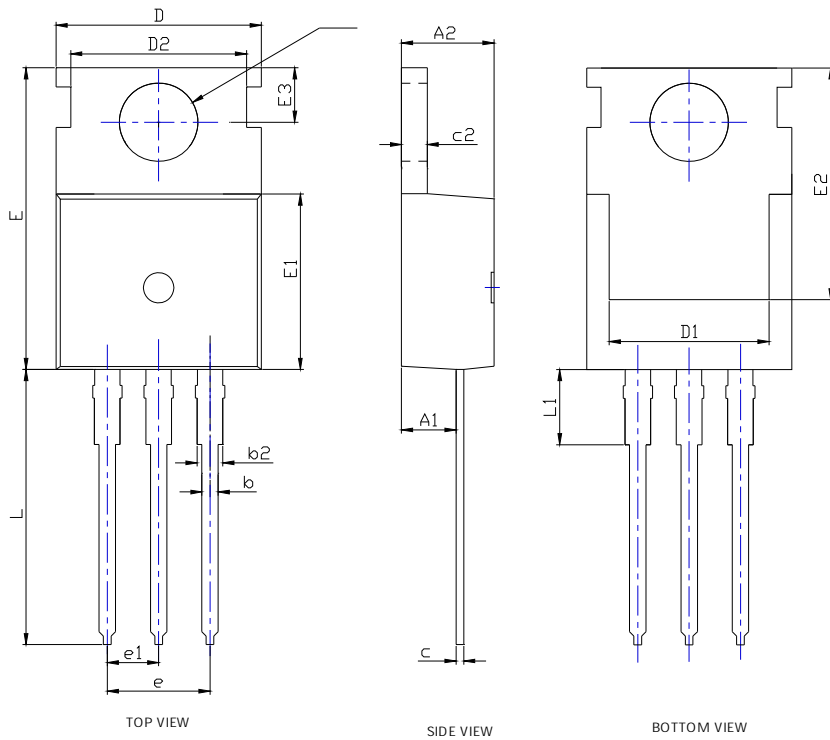

SYMBOL	DIMENSIONS			
	INCHES		Millimeter	
	MIN.	MAX.	MIN.	MAX.
A1	0.091	0.098	2.300	2.500
A2	0.173	0.181	4.400	4.600
b	0.028	0.035	0.700	0.900
b2	0.049	0.056	1.250	1.420
c	0.018	0.022	0.450	0.550
c2	0.049	0.053	1.250	1.350
D	0.382	0.402	9.700	10.200
D1	0.250	0.		



YJP90G12H

Disclaimer

