

DC



YJQ16N025A

Electrical Characteristics ($T_J=25$ unless otherwise noted)

| Parameter | Symbol | Conditions | Min | Typ | Max | Units |
|---------------------------------------|--------------|----------------------------------|-----|-----|-----------|-------|
| Static Parameter | | | | | | |
| Drain-Source Breakdown Voltage | BV_{DSS} | $V_{GS}=0V, I_D$ | 25 | - | - | V |
| Zero Gate Voltage Drain Current | I_{DSS} | $V_{DS}=25V, V_{GS}=0V$ | - | - | 1 | |
| | | $V_{DS}=25V, V_{GS}=0V, T_J=150$ | - | - | 100 | |
| Gate-Body Leakage Current | I_{GSS} | $V_{GS}= \pm 20V, V_{DS}=0V$ | - | - | ± 100 | nA |
| Gate Threshold Voltage | $V_{GS(th)}$ | $V_{DS}= V_{GS}, I_D$ | 1 | 1.5 | 2.5 | V |
| Static Drain-Source On-Resistance | $R_{DS(ON)}$ | $V_{GS}=10V, I_D=10A$ | - | 4.5 | 6 | |
| | | $V_{GS}=4.5V, I_D=6A$ | | 7.5 | 10 | |
| Diode Forward Voltage | V_{SD} | $I_S=10A, V_{GS}=0V$ | - | - | 1.2 | V |
| Gate resistance | R_G | $f=1MHz$ | - | 2.5 | - | |
| Maximum Body-Diode Continuous Current | I_S | | - | - | 16 | A |



Typical Electrical and Thermal Characteristics Diagrams

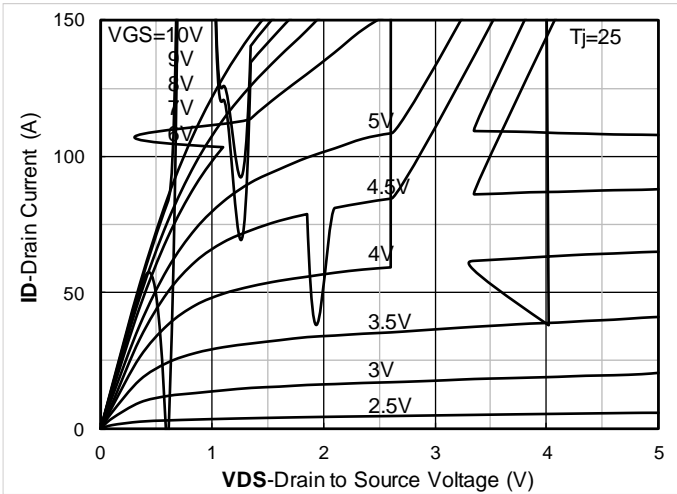

Figure 1. Output Characteristics



Figure 2. Transfer Characteristics

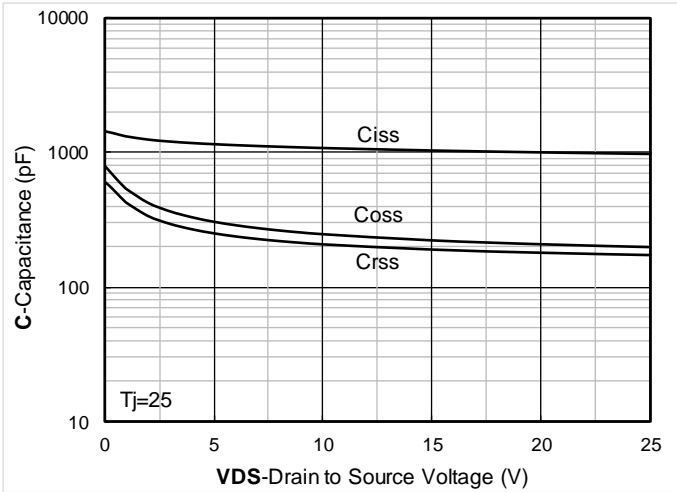

Figure 3. Capacitance Characteristics

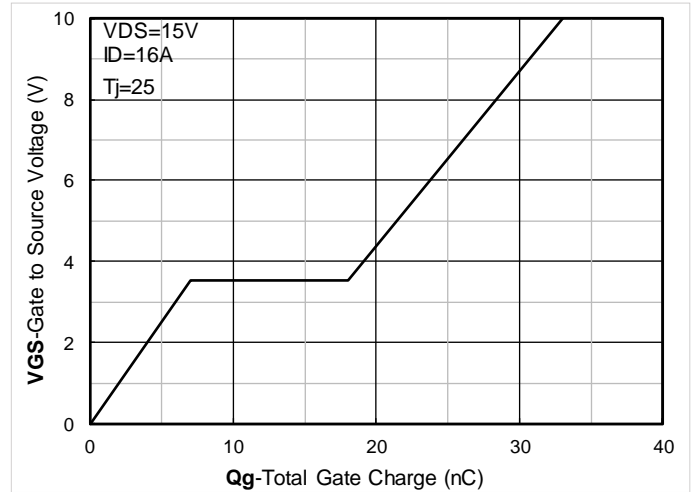

Figure 4. Gate Charge

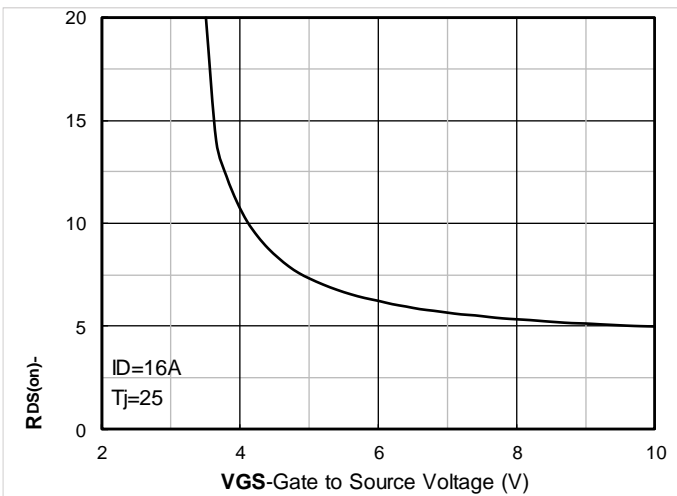

Figure 5. On-Resistance vs Gate to Source Voltage

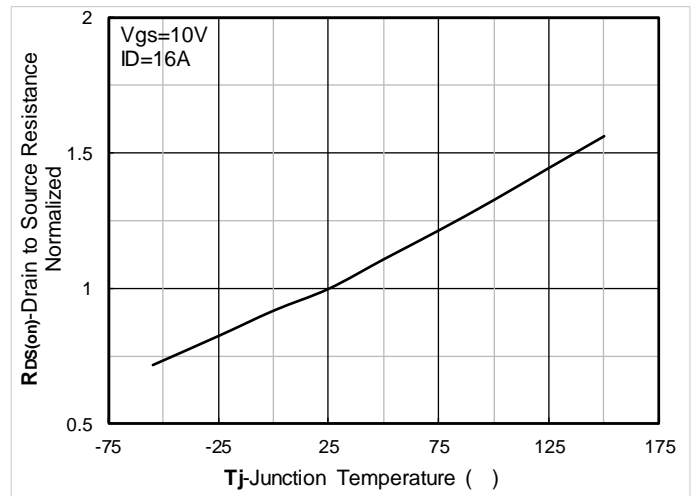

Figure 6. Normalized On-Resistance



YJQ16N025A

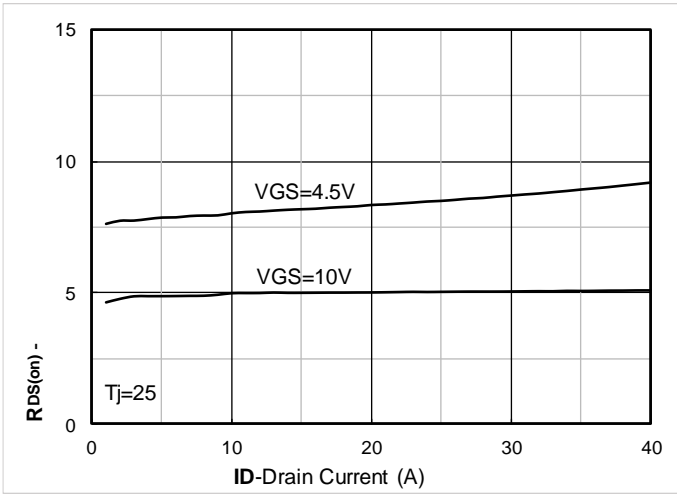

Figure 7. RDS(on) VS Drain Current

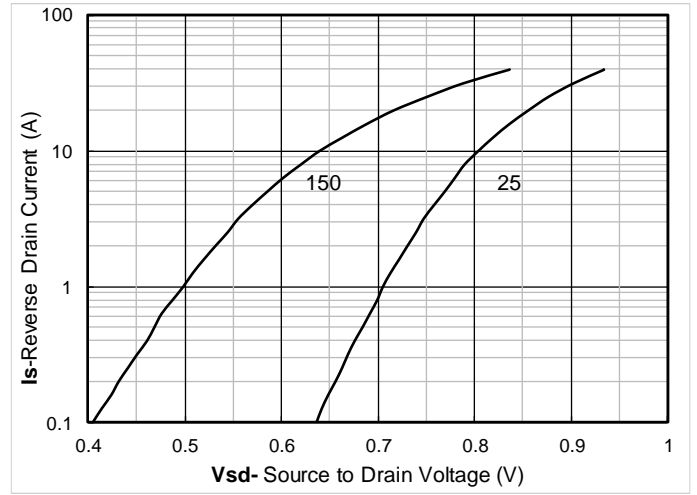

Figure 8. Forward characteristics of reverse diode

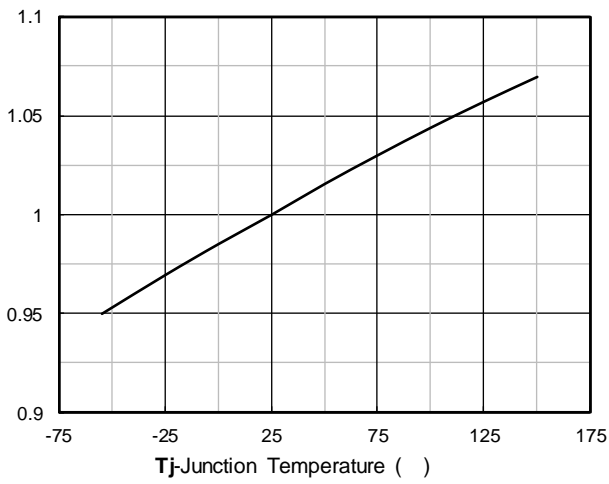

Figure 9. Normalized breakdown voltage

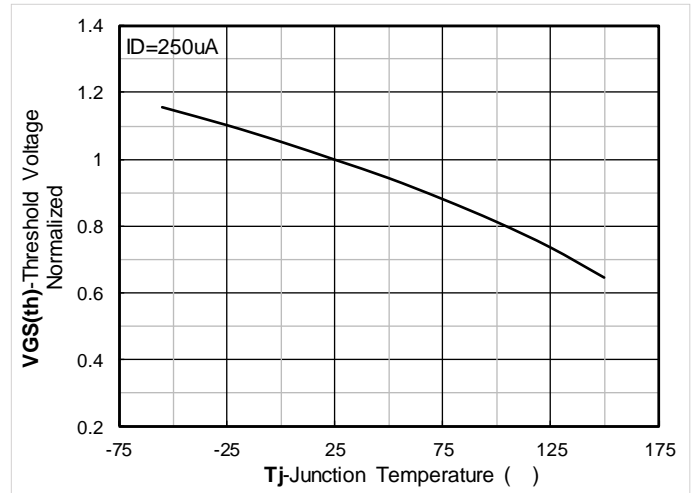

Figure 10. Normalized Threshold voltage

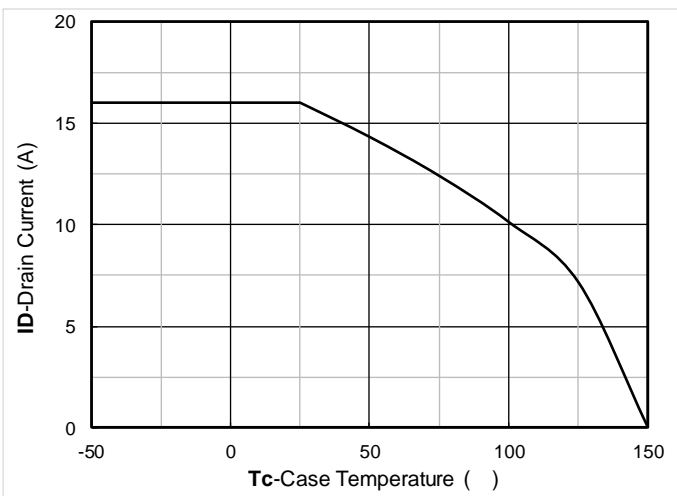

Figure 11. Current dissipation

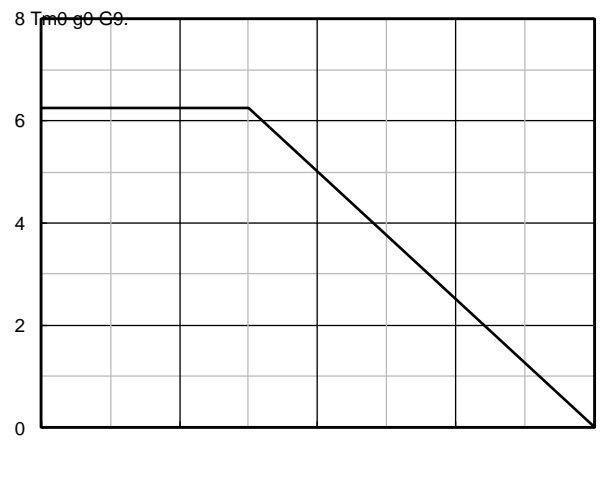
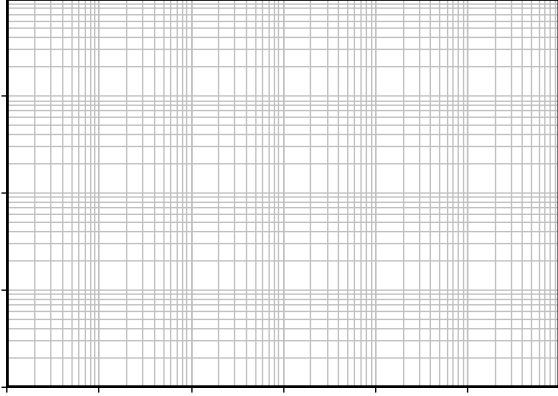

Figure 12. Power dissipation



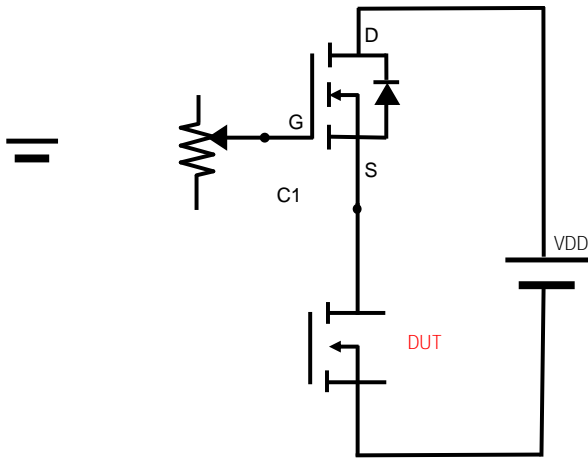

Figure B. Gate Charge Test Circuit & Waveform

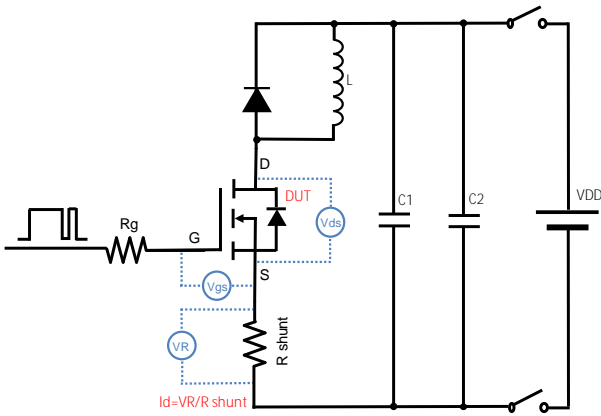

Figure C. Resistive Switching Test Circuit & Waveform

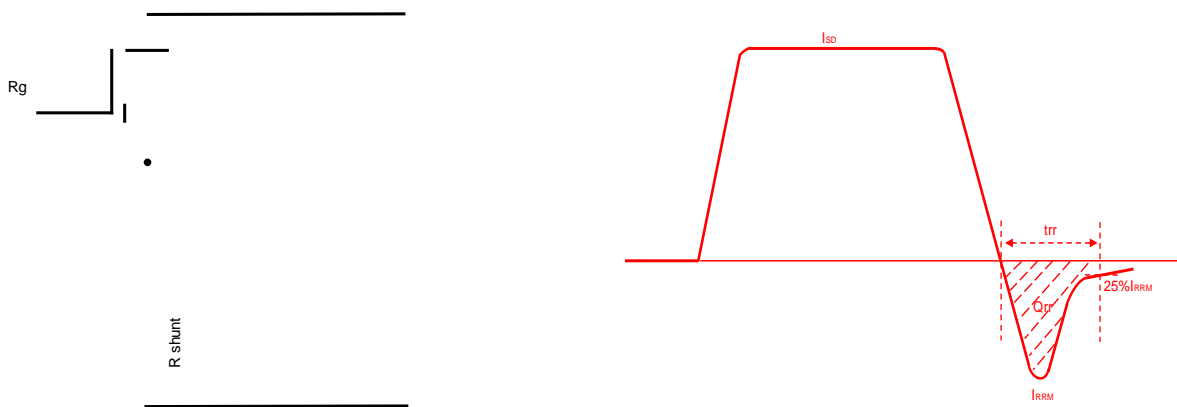

Figure D. Diode Recovery Test Circuit & Waveform

YJQ16N025A



YJQ16N025A

Disclaimer

The information presented in this document is for reference only. Yangzhou Yangjie Electronic Technology Co., Ltd. reserves the right to make changes without notice for the specification of the products displayed herein to improve reliability, function or design or otherwise.

The product listed herein is designed to be used with ordinary electronic equipment or devices, and not designed to be used with equipment or devices which require high level of reliability and the malfunction of which would directly endanger human life (such as medical instruments, transportation equipment, aerospace machinery, nuclear-reactor controllers, fuel controllers and other safety devices), Yangjie or anyone on its behalf, assumes no responsibility or liability for any damages resulting from such improper use of sale.

This publication supersedes & replaces all information previously supplied. For additional information, please visit our website <http://www.21yangjie.com>