





# YJQ70G06A

## Electrical Characteristics ( $T_J=25$ unless otherwise noted)

Parameter	Symbol	Conditions	Min	Typ	Max	Units
<b>Static Parameter</b>						
Drain-Source Breakdown Voltage	$BV_{DSS}$	$V_{GS}=0V, I_D=250\mu A$	60	-	-	V
Zero Gate Voltage Drain Current	$I_{DSS}$	$V_{DS}=60V, V_{GS}$				



Typical Electrical and Thermal Characteristics Diagrams

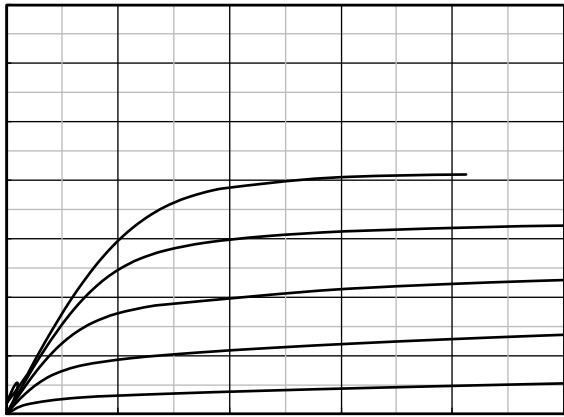

Figure 1. Output Characteristics

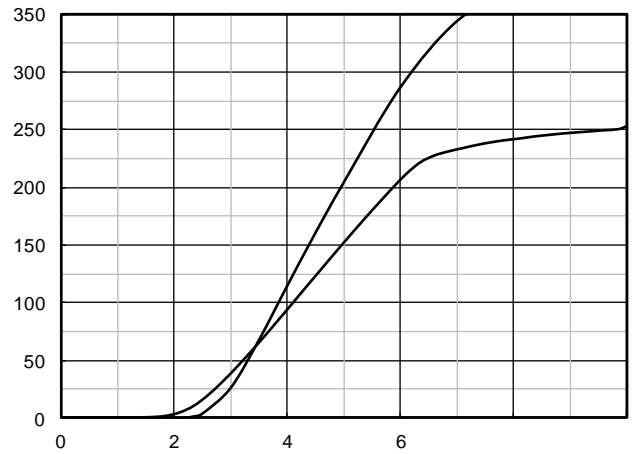

Figure 2. Transfer Characteristics

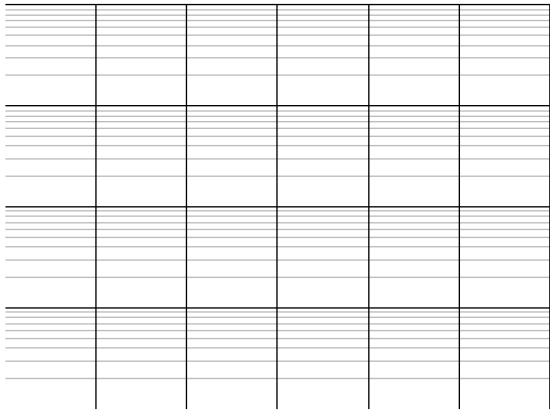

Figure 3. Capacitance Characteristics

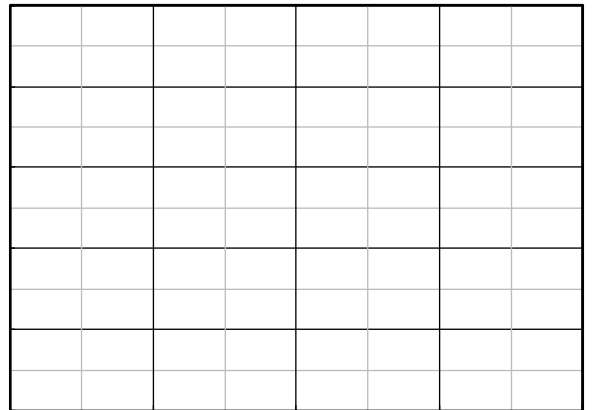

Figure 4. Gate Charge

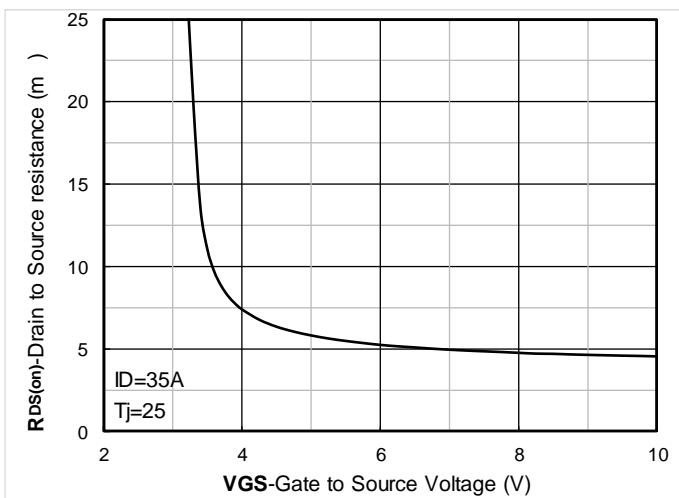
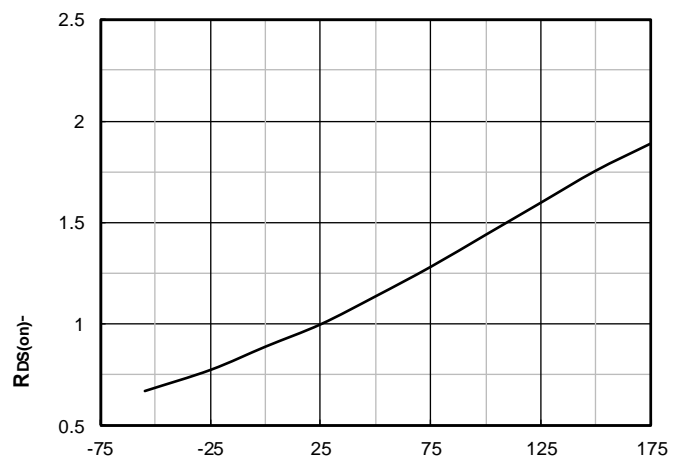

Figure 5.





# YJQ70G06A

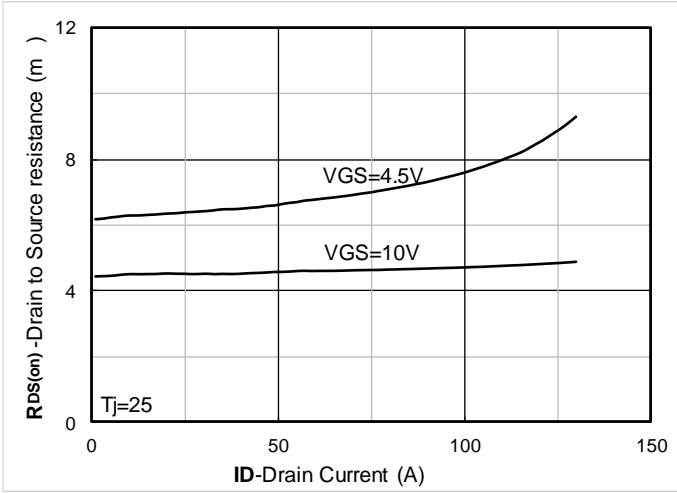

Figure 7. RDS(on) VS Drain Current

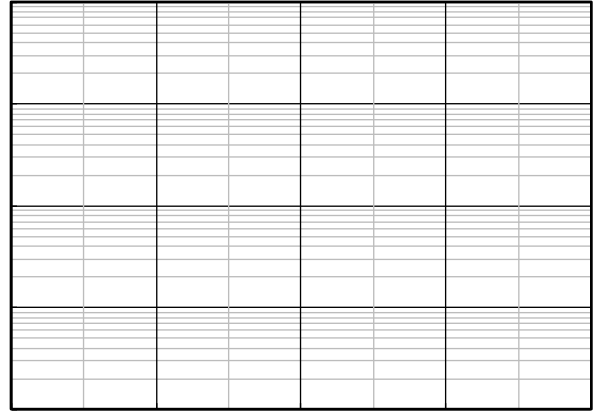

Figure 8. Forward characteristics of reverse diode

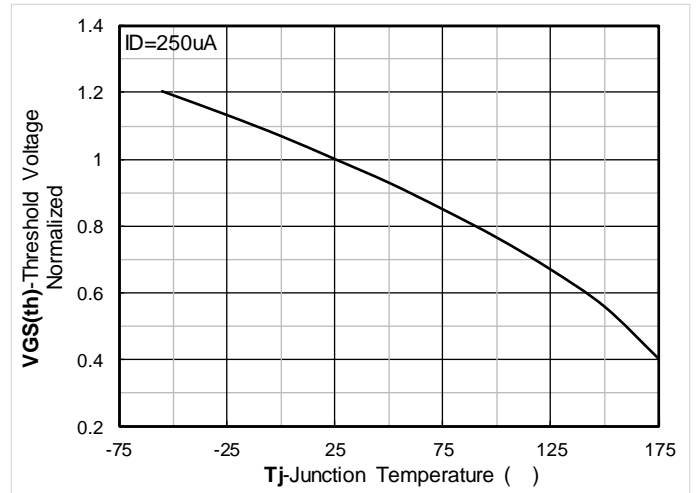
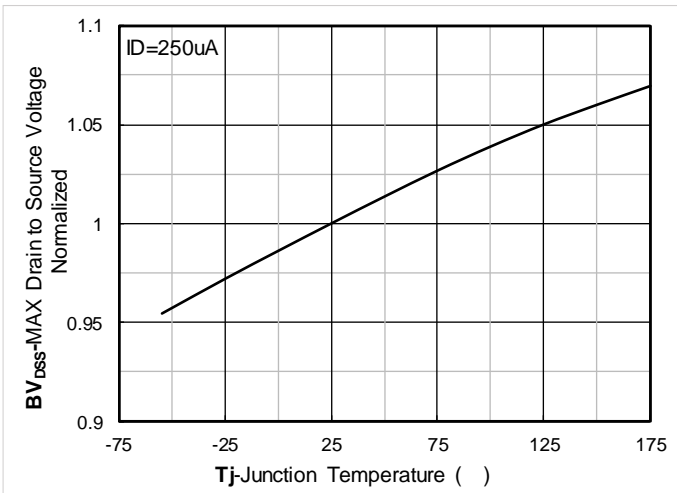

Figure 9. Normalized breakdown v8821Q EMC /P ÅCID 4/Lang (en6 355ag0008882 0 596.04 842.04 reW\* nBT/F5 9

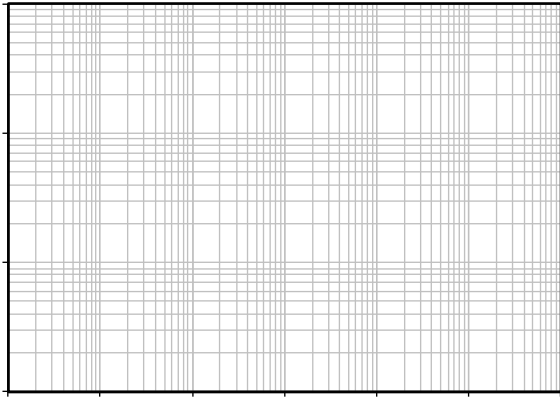

Figure 13. Maximum Transient Thermal Impedance

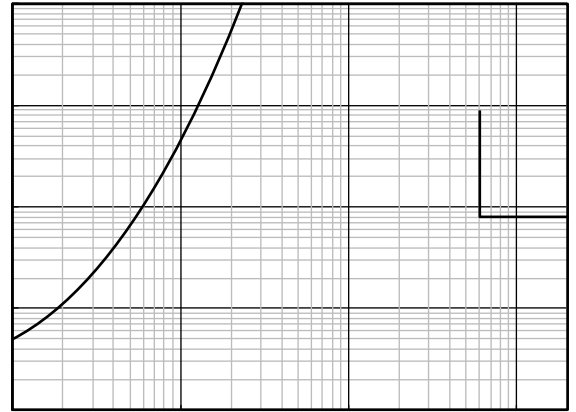

Figure 14. Safe Operation Area

## Test Circuits & Waveforms



Figure A. Unclamped Inductive Switching (UIS) Test Circuit & Waveform



# YJQ70G06A

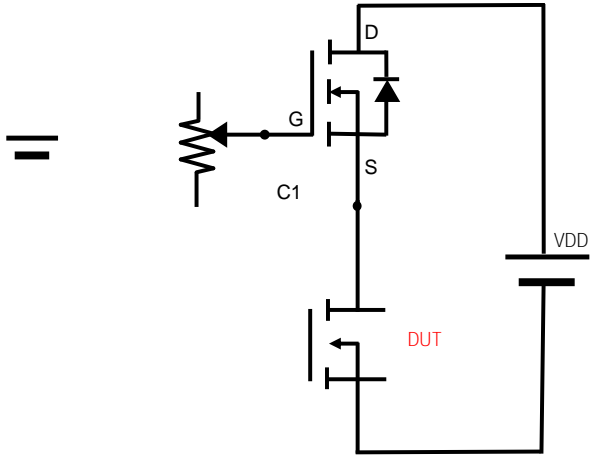



DFN3333-8L-A-0.8MM Package information

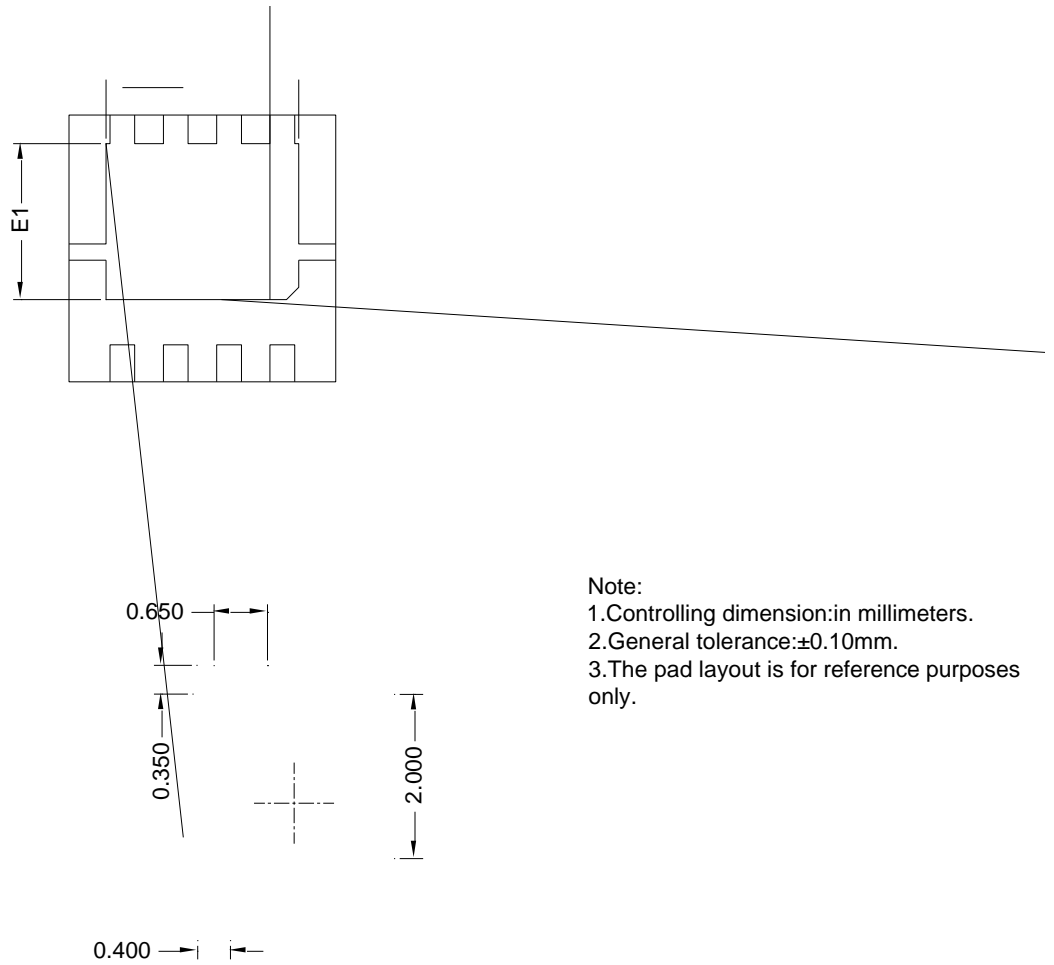

Suggested Solder Pad Layout  
Top View



**Disclaimer**

The information presented in this document is for reference only. Yangzhou Yangjie Electronic Technology Co., Ltd. reserves the right to make changes without notice for the specification of the products displayed herein to improve reliability, function or design or otherwise.

The product listed herein is designed to be used with ordinary electronic equipment or devices, and not designed to be used with equipment or devices which require high level of reliability and the malfunction of which would directly endanger human life (such as medical instruments, transportation equipment, aerospace machinery, nuclear-