



YJQD25N01A

N Channel Enhancement Mode Field Effect Transistor
Product Summary

General Description

Applications

Absolute Maximum Ratings

Parameter	Symbol	Limit	Unit
-----------	--------	-------	------



Typical Performance Characteristics

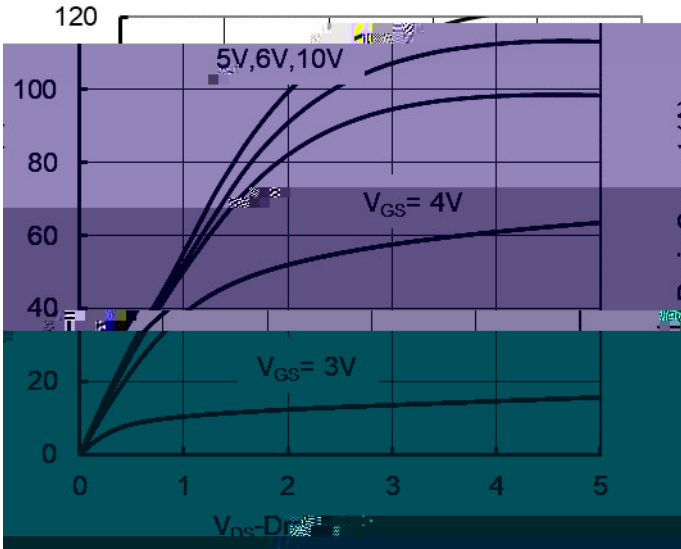

Figure 1. Output Characteristics

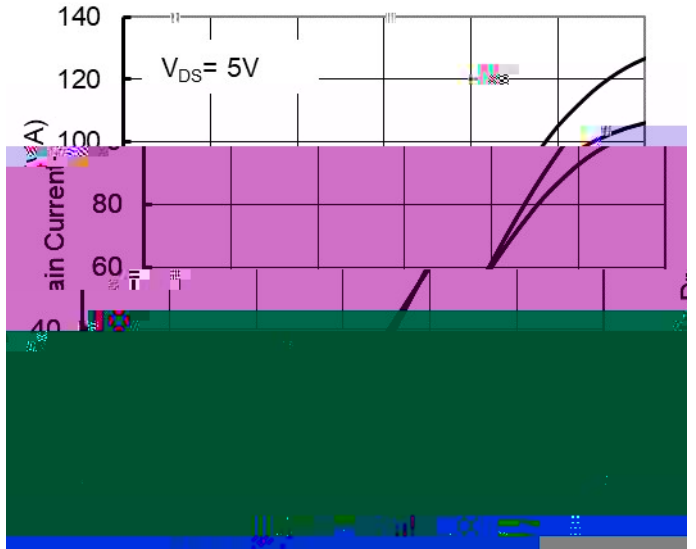

Figure 2. Transfer Characteristics

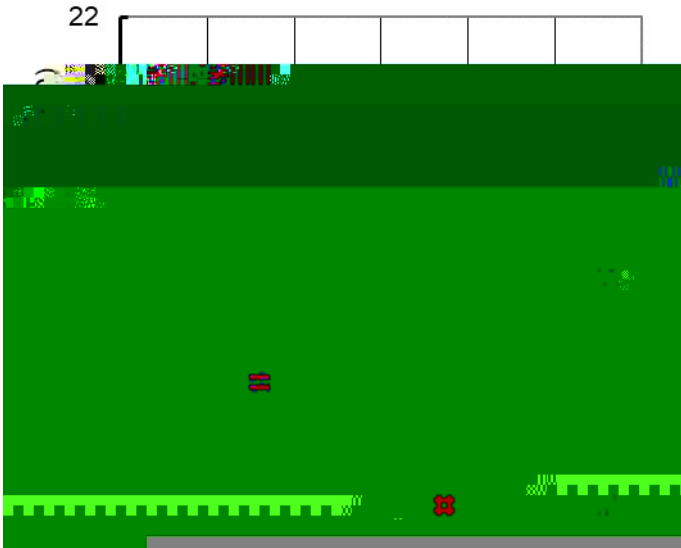

Figure 3. On Resistance vs. Drain Current

4 . Q gup h ni " ^ i T

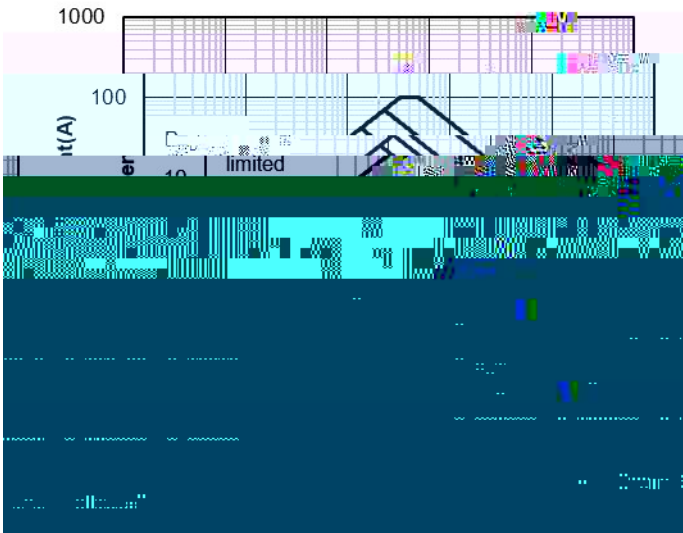

Figure 7 Safe Operation Area

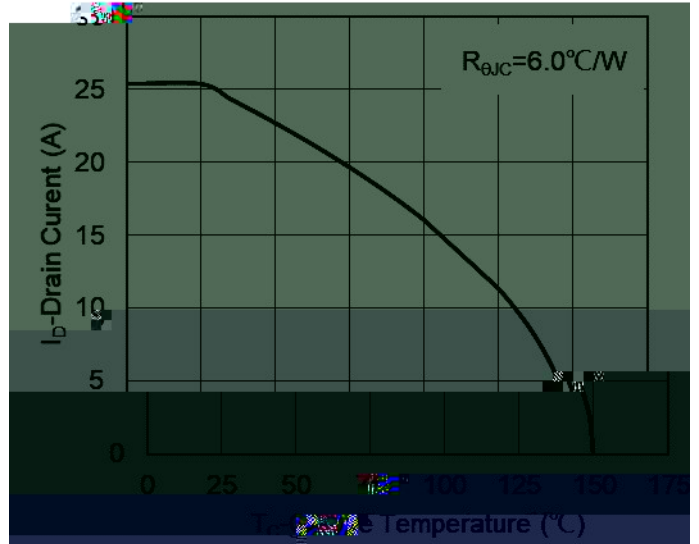

Figure 8 Maximum Continuous Drain Current vs Case Temperature

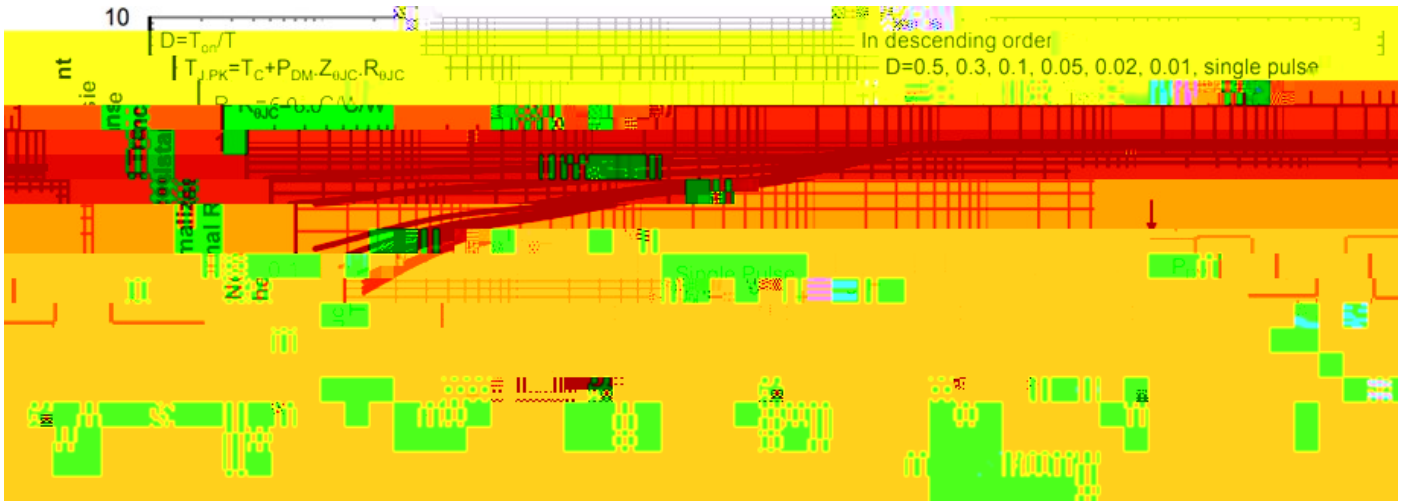
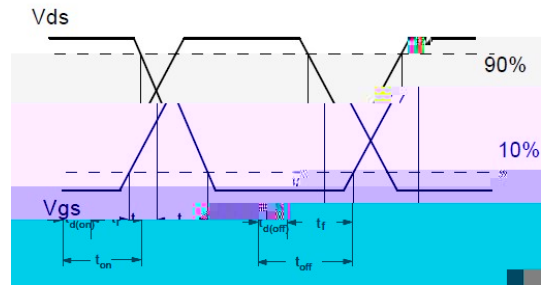
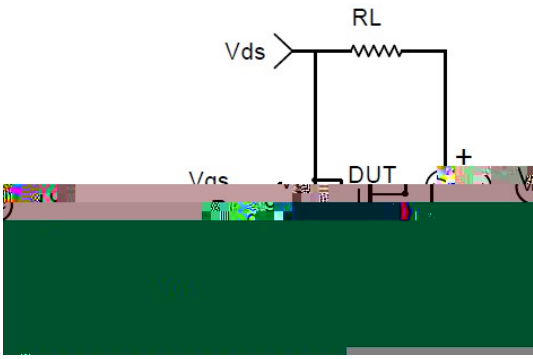

Figure 9 Normalized Maximum Transient Thermal Impedance



YJQD25N01A



Resistive Switching Test Circuit & Waveforms

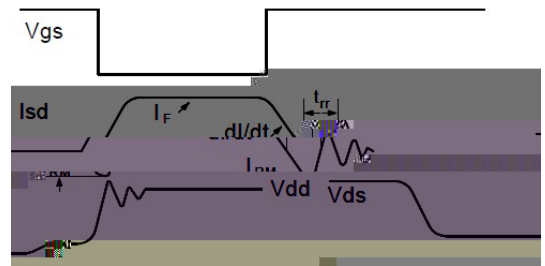
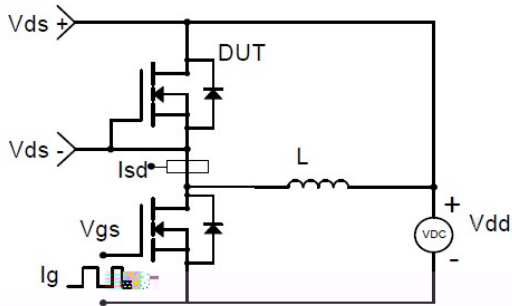

Diode Recovery Test Circuit & Waveforms

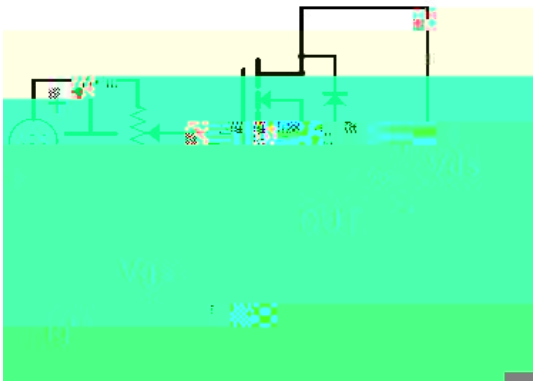



YJQD25N01A

DFN33x33 Package information

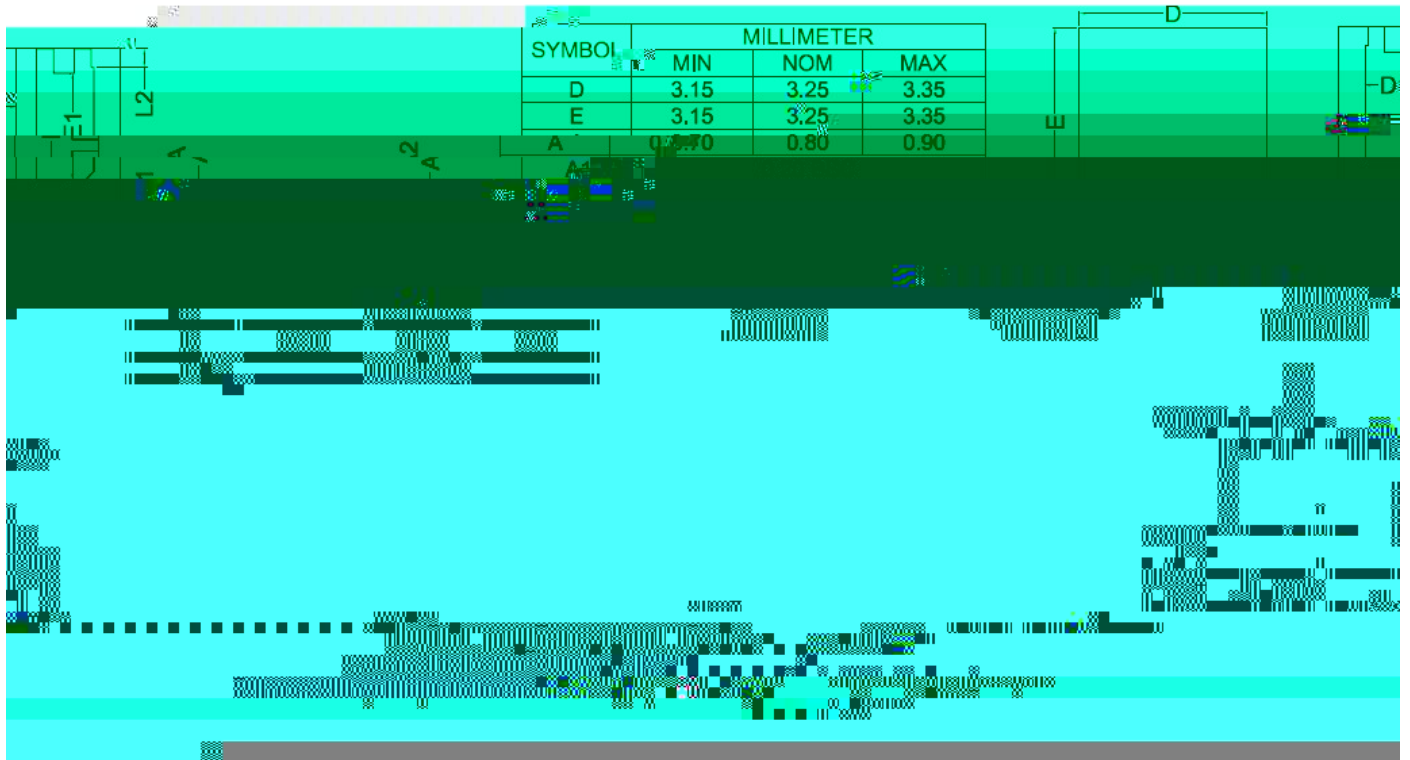



YJQD25N01A

Disclaimer
